

DATA SHEET

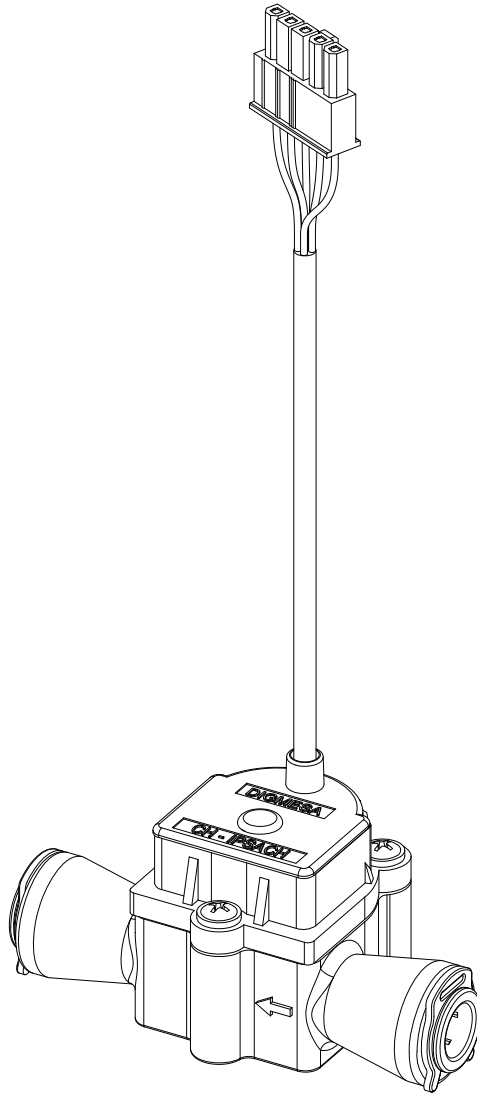

DIGIMESA[®]
CHOOSE THE ORIGINAL

FHKU Speedfit 3/8" CombiSensor digital
Part number: 938-75xx/xTL02

Digimesa AG, Keltenstrasse 31, CH-2563 Ipsach / Switzerland
Phone +41 (32) 332 77 77, Fax +41 (32) 332 77 88

www.digimesa.com Version 01 FHKU Speedfit 3/8" CombiSensor digital 938-75xx/xTL02 GB Page 1-13

General Description

The CombiSensor has been designed for all applications where Flow, Temperature and Conductivity must be measured in a very compact form. The CombiSensor calculates the temperature compensation of the conductivity value, based on the measured temperature and a compensation factor 2.25% per °C. The conductivity measurement value is therefore "temperature-compensated".

The "CombiSensor digital" comes with a RS-485 Interface (Modbus protocol). The configuration of the CombiSensor can be modified with standard MODBUS functions. The device is adequate for the waterfilter industry (e.g. compact RO equipment).

Approvals / Standards

EN55014-1:00+A1:01+A2:02, EN61000-6-3:01+A11:04, IEC61000-6-3:06(ed.2.0), EN61000-3-2:06, IEC61000-3-2:05(ed.3.0), EN61000-3-3:95+A1:01+A2:05, IEC61000-3-3:94+A1:01+A2:05(Cons.ed 1.2), EN55014-2:97+A1:01, EN61000-6-1:01, IEC61000-6-1:05(ed.2)



Material:

Housing:	PBT 35%GF
Bearing pin:	Inox 1.4305
Probes:	Temperature Inox 1.4598 Conductivity Inox 1.4598
Nozzle:	Ø 1.0, 1.2, 2.0, 2.5mm PPS 40%GF
Nozzle:	Ø 3.0, 4.0mm Inox 1.4305
Nozzle:	Ø 5.6mm like housing
O-ring:	MVQ (Silikon) FPM (Viton) / EPDM on request
Turbine:	PVDF 2 Magnets
Magnete:	Ceramic Sr Fe O (in contact with the medium)
Screws:	PT-screws (Phillips cross recessed)

Measurement characteristics:

Flow rate:	0.041 - 15 l/min depending on the nozzle diameter
Nozzle size:	Ø 1.0, 1.2, 2.0, 2.5, 3.0, 4.0, 5.6mm
Continuous operation:	< 500 rpm
Measuring accuracy:	+/- 2.0%
Repetition:	< +/- 0.25%
Conductivity:	0 - 20'000 µS/cm
Measuring accuracy:	± 3%
Response time:	0.5 sec.
Temperature:	0°C to + 65 °C
Measuring accuracy:	± 0.5 °C (under flow condition)
Response time probe:	7 sec.

Electrical connection ratings:

Power supply:	+ 5VDC to + 24VDC (+/- 10%)
Consumption:	max. 30mA
Pulse output:	Open collector NPN
Signal load:	max. 20 mA
Serial port:	RS-485 Half Duplex (2-wire) (9600 baud, even parity, 8 bits binary, 1 stop bit)
Communication protocol:	Modbus RTU
Cable:	5-Pol Cable 5 x 0.14mm ²
Connector:	Molex Mini-Fit Jr. UL94V-0

Technical data:

Temperature range:	as shown on page 3
Pressure range:	as shown on page 3
Mounting position:	Horizontal *

Dimensions in mm:

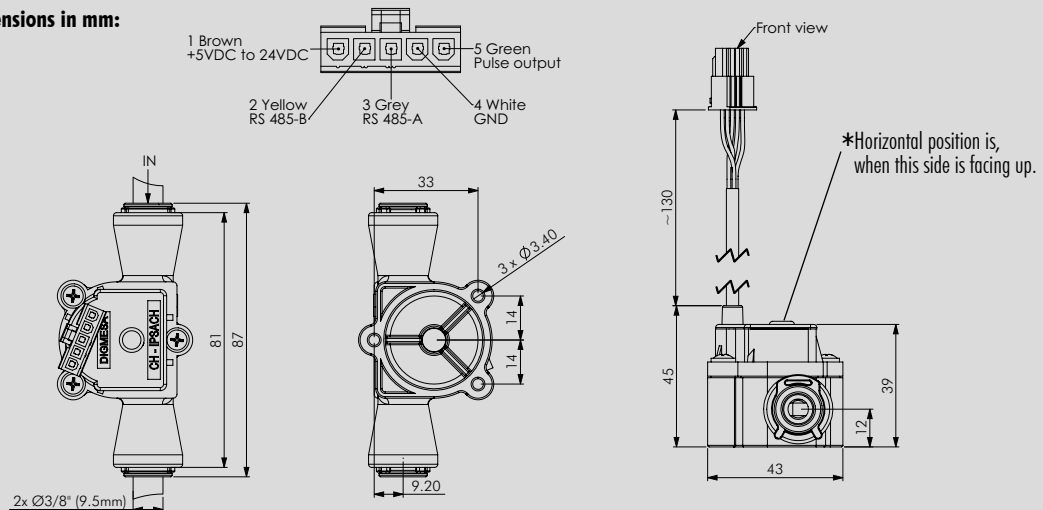

CABLE PINOUT

Cable color	Description
Brown	+ 5VDC to + 24VDC
White	GND (Sensor Ground)
Grey	RS 485A
Yellow	RS 485B
Green	Pulse output (Open collector NPN)

MEASUREMENT

The flow measurement may differ depending on medium and installation. We recommend to calibrate the number of pulses per liter in line with the complete installation"

RESISTANCE

Special regulations which must be complied with by the flowmeter manufacturer apply to each country, e.g. CE, NSF, FDA and SK. The various media flowing through the flowmeter differ from application to application. You are advised to enquire with the medium manufacturer as to whether the entire installation and the flowmeter are resistant to the medium itself (see Material)!

Technical Specification

Working Pressure and Temperature Range

Super Speedfit fittings are suitable for the following pressures and temperatures.

Temp.	Pressure	
	5/32" - 5/16" 4mm - 8mm	3/8" - 1/2" 10mm - 22mm
Air		
- 20°C	16 Bar	10 Bar
Potable Liquids and Air		
+1°C	16 Bar	10 Bar
+20°C	16 Bar	10 Bar
+65°C	10 Bar	7 Bar

Also suitable for vacuum

Depending on the tube used, under certain conditions fittings may be used at higher pressures and temperatures. Please refer to our Customer Services Department for guidance. Note 1 Bar = 14.5 PSIG.

Tube Types

Plastic Tube - Polyethylene, nylon and polyurethane conforming to the tolerances shown below. For soft tubing or thin wall tube we recommend the use of tube inserts.

Braided Tube - Use of Tube to Hose Stems listed on pages 5 and 12 is essential when using tube. Use of clamps to retain braided tube on barbs is recommended.

Metal Tube (soft) - Brass, copper or mild steel conforming to the tolerances below.

Metal Tube (hard) - We do not recommend Super Speedfit fittings for hard metal or chromium plated tubes.

For stainless steel and other polished metal tubes we recommend the use of Superseal fittings. These are shown on page 9 of this brochure. It is essential that outside diameters be free from score marks and that the tube be deburred before inserting the fitting.

Tube Tolerances

Super Speedfit fittings are offered for tubes with outside diameters to the following tolerances.

Size (inches)	5/32 - 3/16	1/4 - 1/2
Tolerance (inches)	+0.001 / -0.003	+0.001 / -0.004
Size (mm)	4mm - 5mm	6mm - 22mm
Tolerance (mm)	+0.05 / -0.07	+0.05 / -0.10

Installation and System Testing

Fittings and tube should be kept clean and undamaged before use.

All tube and fittings installations must be pressure tested after installation to ensure system integrity before handing over to the final user. See also "How to make a connection".

1/4 Turn Valves

These valves have been designed to allow temporary servicing of downstream equipment and must only be used in the fully open or fully closed position. **DO NOT USE THESE VALVES:** In a partially open position to control flow; to provide a permanent termination; without tubing assembled or plugged (or threaded connections sealed, or as a tap or "faucet".

Chemicals

For use with chemicals or other potentially aggressive liquids, please refer to our Customer Services Department.

Super Speedfit fittings are not recommended for use with explosive gases, petroleum spirits, and other fuels or for central heating systems.

Collet Covers

Are available as additional security against removal of the tube or to provide a simple means of colour coding. The cover is offered in a range of six colours. Please see page 26 of this brochure.

Collet Covers

Are available as additional security against removal of the tube or to provide a simple means of colour coding. The cover is offered in a range of six colours. Please see page 26 of this brochure.

Food Quality

All the fittings in the brochure are produced in Food and Drug Administration (FDA) approved materials and are therefore recommended for food quality applications.

Maximum Torque Values for Plastic Threads BSP, BSPT & NPT.

Plastic threads are not generally as strong as brass threads. Customers and end users should be aware of this when choosing products for their applications. Overtightening of plastic threads will cause undue stress and eventual cracking and leakage. The maximum torque figures for BSP and BSPT threads used on John Guest fittings in mating threads conforming to the relevant BS or International thread standards are shown below.

	Threads		
	1/8 - 1/4	3/8 - 1/2	3/4
Max. Torque	1.5Nm	3.0Nm	4.0Nm

John Guest recommend OEM customers to consider replacing threaded ports with the more modern Cartridge Systems.

It is recommended that all installations are checked prior to use to determine that a seal has been made.

Maintenance and Replacement Intervals

John Guest products generally require little maintenance but as a minimum we recommend routine visual inspection. Frequency of visual inspection will depend on severity of application and risk of failure. If after visual inspection John Guest products appear damaged, cracked, charred, discoloured, heat distorted or corroded they should be replaced. Any product that is or appears to be leaking should be replaced.

Product life is affected by the severity of the application, the hostility of the working environment and contact with aggressive chemicals or liquids. It is therefore important that specific replacement intervals be considered by specifiers/users/customers based on previous service life or when failure could result in unacceptable downtime, damage or injury risk.

Cleaners and Sanitising of Acetal Fittings

The external surfaces of John Guest products must not come into contact with oxidising or acidic cleaners and sanitising agents, for example (but not limited to) those below pH 4, high in sodium hypochlorite level (bleach) or containing hydrogen peroxide. Our plastic material suppliers recommend ECOLAB Oasis 133 as a suitable cleaner for the external surfaces of acetal products manufactured by John Guest.

Several different methods exist for sanitising the internal surfaces of fluid systems, including sodium hypochlorite, hydrogen peroxide, chlorine dioxide or ozone. It is entirely the responsibility of the end user to determine if the chosen method is suitable for use with John Guest products over the planned working life of the system. However, to avoid unnecessary early failure, John Guest requires that the disinfection solution must be immediately flushed out at all draw off points with fresh, wholesome water at the end of the disinfection period. **The solution must not be left in the system.** Disinfection solutions must only come into contact with the internal (fluid carrying) surfaces of the system. If any other surfaces of a fitting come into contact with disinfection solution **the whole fitting must be replaced immediately.** Details of which products are made from Acetal are shown in our catalogues but generally John Guest products incorporating Acetal are designated by the part number prefix PI, PM, CI, CM and RM. Polypropylene fittings offer greater resistance to aggressive chemicals than Acetal fittings. Polypropylene does not have the same mechanical properties as Acetal and John Guest polypropylene fittings are generally designated by the part number prefix PP or PPM.

Side Loads

Fittings should not be subject to excessive side loads and they should not be used as support brackets. Tubing and fittings should be adequately supported to prevent excessive side loading.

Warranty

Whilst we give a warranty against defects in manufacture or materials, it is the responsibility of the specifier to ensure that fittings and related products are suitable for their application. The installation must be carried out correctly in accordance with our recommendations, complying with recognised codes of practice and relevant national standards, and be properly maintained. Please refer to our terms and conditions of sale.

www.johnguest.com

34

Important:

Secures the collet in its position to prevent an accidental disconnection of the tube.



We reserve the right to make modifications in the interests of technical progress.

Version 01 FHKU Speedfit 3/8" CombiSensor digital 938-750v/xTL02 GB Page 3-13

Modbus Register Map

Input Registers (Read only):

Read out corresponding registers with function code 4 (0x04) (Read Input Registers).

Sensor data registers:

Input Register	Address dec	Address hex	Description	Data type	Ratio	Unit	Value range	Example	Remarks
30001	0	0x0000	Volume	16 Bit unsigned integer	1:1	[L]	0-65535	100 => 100 Liter since last power up	Not stored in non volatile memory! The same volume is also present in holding register 40001 Volume , for performing a reset.
30002	1	0x0001	Flow rate	16 Bit unsigned integer	1:1	[ml/min]	0-65535	500 => 500ml/min	Actual flowrate
30003	2	0x0002	Conductivity	16 Bit unsigned integer	1:1	[μ S/cm]	0-65535	10000 => 10000 μ S/cm	Compensated if holding register 40006 Temperature compensation is set (Default)
30004	3	0x0003	Temperature	16 Bit unsigned integer	10:1	[$^{\circ}$ C]	0-1250	276 => 27.6 $^{\circ}$ C	value 0xffff => temp sensor failure
30005	4	0x0004	Conductivity uncompensated	16 Bit unsigned integer	1:1	[μ S/cm]	0-65535	10000 => 10000 μ S/cm	Always uncompensated conductivity.

Sensor software number registers:

Input Register	Address dec	Address hex	Description	Data type	Ratio	Unit	Value range	Example	Remarks
30101	100	0x0064	SW Version number	16 Bit unsigned integer	1:1	---	0-65535	0x0103 => V1.3	representating 639-9076/ V1.3
30102	101	0x0065	SW number low	16 Bit unsigned integer	1:1	---	0-65535	9076 (low number)	representating 639- 9076 /V1.3
30103	102	0x0066	SW number high	16 Bit unsigned integer	1:1	---	0-65535	639 (high number)	representating 639 -9076/V1.3

DIGMESA

Holding Registers (Read/Write):

Read out corresponding registers with function code 3 (0x03) (Read Holding Registers)

Write corresponding registers with function code 6 (0x06) (Write Single Register).

Sensor data registers:

Holding Register	Address dec	Address hex	Description	Data type	Ratio	Unit	Value range	Default	Remarks
40001	0	0x0000	Volume	16 Bit unsigned integer	1:1	[L]	0-65535	0 => 0 Liter	Read and writable volume (Same as Input Register 30001 Volume). By writing e.g. a value of 0 the volume can be resetted. Not stored in non volatile memory!

Sensor settings registers:

Holding Register	Address dec	Address hex	Description	Data type	Ratio	Unit	Value range	Default	Remarks
40101	100	0x0064	Offset Temperature	16 Bit signed integer	10:1	[°C]	-32768 to +32767	0	A value of e.g. -15 lowers the temperature by 1.5 °C.
40102	101	0x0065	Offset Conductivity	16 Bit signed integer	10:1	[µS/cm]	-32768 to +32767	0	A value of e.g. +43 increases the conductivity by 4.3 uS/cm.
40103	102	0x0066	Slope Conductivity	16 Bit unsigned integer	1:1	---	0-65535	10000	Gain calibration factor
40104	103	0x0067	Reference Temperature	16 Bit unsigned integer	1:1	---	0: 20 °C 1: 25 °C	1: 25 °C	1: 25 °C
40105	104	0x0068	Temperature compensation factor	16 Bit unsigned integer	100:1	[%/°C]	0-65535	225	A factor of e.g. 225 compensates linearly the conductivity by 2.25%/°C around the reference temperature.
40106	105	0x0069	Temperature compensation	16 Bit unsigned integer	1:1	---	0: Temp. comp OFF 1: Temp. Comp ON	1: Temp. Comp ON	If temperature compensation is ON, the conductivity in input register 30003 Conductivity is temperature compensated.
40107	106	0x006A	Pulses per liter	16 Bit unsigned integer	1:1	[#/l]	20-65535	see impuls value in the data sheet	Specific to sensor type and nozzle size.
40108	107	0x006B	Pulse averaging (Digital filter)	16 Bit unsigned integer	1:1	---	0: 1 Pulse 1: 2 Pulses 2: 4 Pulses 3: 8 Pulses 4: 16 Pulses 5: 32 Pulses	0: 1 Pulse	Pulse averaging for flow calculation, used for the Flow in input register 30001 Flow rate .
40109	108	0x006C	Slave ID	16 Bit unsigned integer	1:1	---	1-247	1	For connecting more than one sensor to the same bus individual slave ID's can be set.
40110	109	0x006D	Response Delay	16 Bit unsigned integer	1:1	[baud cycles]	0-1000	340	Delay in baud cycles after the sensor (slave) responds to the master after reception of the request. This value is depending on the master UART and is for compatibility purposes.

CONNECTION

Typical Modbus connection diagram

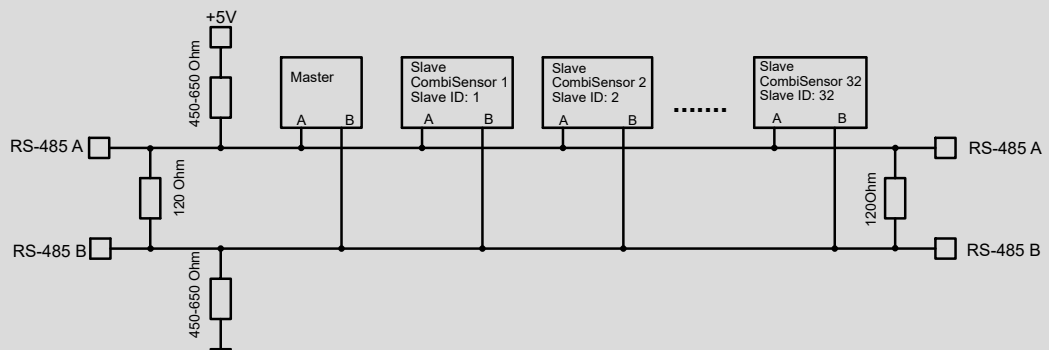

Notes:

- In addition the sensor GND can be connected between Master and slaves for limiting common mode voltages.
- Pull-Up/Pull-Down resistors of 450-650 Ohm recommended on RS485-A/RS485-B line.
- One pair of termination resistors of 120 Ohm recommended at each conductor end.
- The CombiSensor has no Pull-Up/Pull-Down resistors and no termination resistor integrated.

Typical Pulse output diagram:

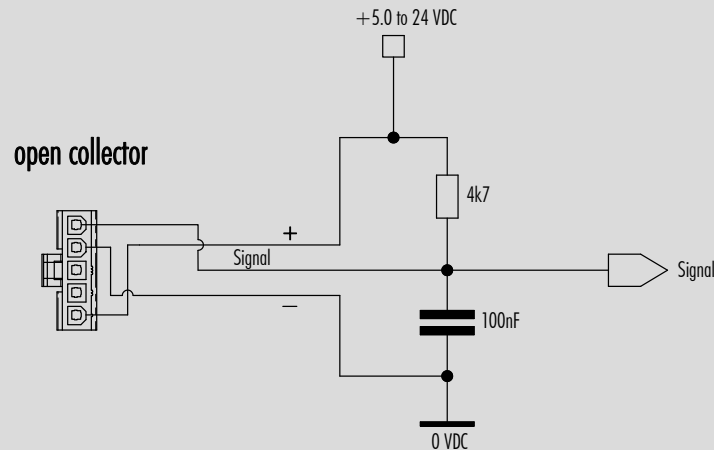

MEASUREMENT CONDUCTIVITY/TEMPERATURE TIPS

- Air bubbles in the sensor can deteriorate conductivity measurement values. Make sure you did well evacuate the air from the sensor.
- For measuring accurate temperature compensated conductivity, flowing medium guarantees optimal temperature condition for the probe.
- The CombiSensor is factory calibrated. If needed, further adjustment can be made by writing to register 40102 (Offset Conductivity) and 40103 (Slope Conductivity).
- The temperature can be adjusted by writing to register 40101 (Offset temperature).

Measurement Curve FHKU Ø1.00mm (#938-7510/FTL02)

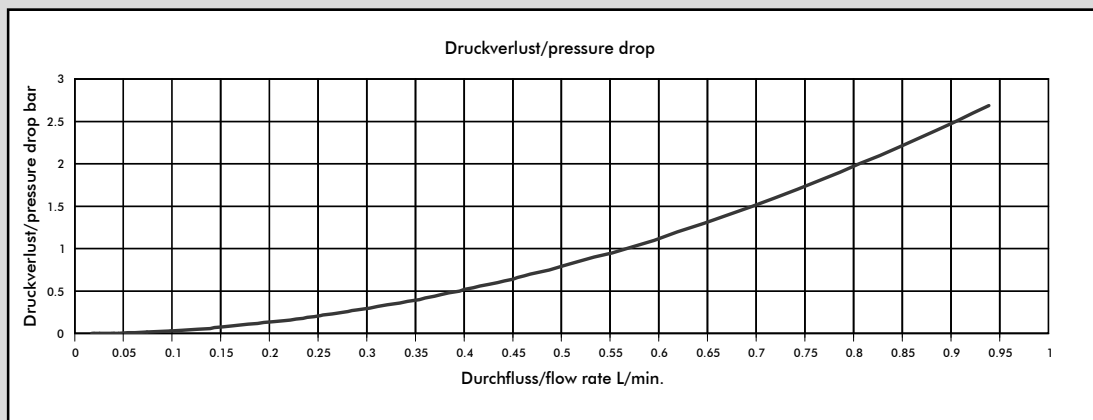
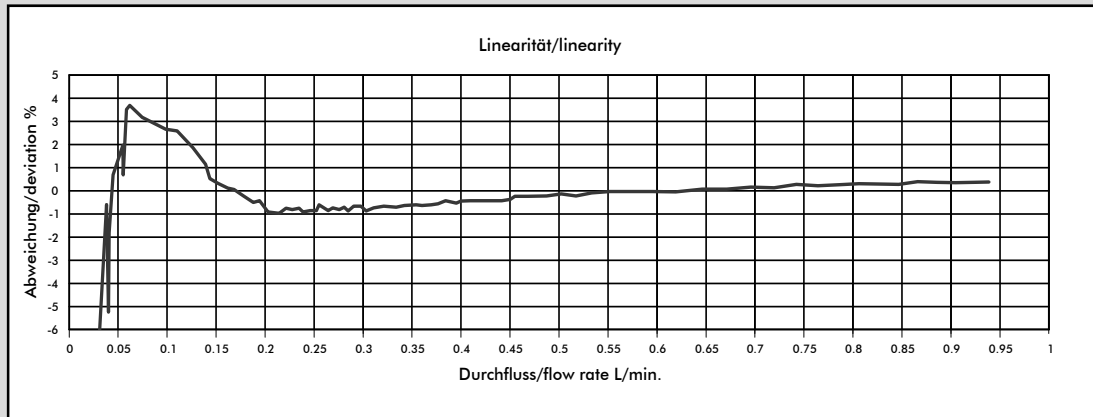

Getestet mit Wasser, max. Druck: 3.3 bar / Tested with water, max. pressure 3.3 bar

Nozzle size	Pulses/litre	g/pulse	min. flow rate in [litres/min] at linear start	max. flow rate in [litres/min]	Pressure loss in [bar]
Ø 1.00 mm	2063	0.48	0.041	0.56	1.0
Ø 1.20 mm	1700	0.59	0.050	0.82	1.0
Ø 2.00 mm	988	1.00	0.091	2.40	1.0
Ø 2.50 mm	760	1.31	0.150	3.74	1.0
Ø 3.00 mm	565	1.76	0.102	5.63	1.0
Ø 4.00 mm	381	2.62	0.123	8.38	0.8
Ø 5.60 mm	236	4.22	0.308	9.26	0.5

MEASUREMENT TIPS

- Ensure that there is no fast-pulsatory movement of the media
- Ensure that there are no reverse pressure surges
- Ensure that there is no air in the system
- Keep the pressure loss as small as possible
- Note the mounting position of the flowmeter
- Min/max flow should be in the linear range of the selected flowmeter
- Clean the system at appropriate intervals
- Avoid electrical current peaks
- Incorrect cabling of power supply +, signal and ground will destroy the flowmeter
- Do not mechanically load electrical contacts
- Avoid moisture on the electrical contacts
- Avoid stray pick-up via the cable (Do not lay cables in parallel with high current loads)

The values specified must be considered as approximate values.

The number of pulses per litre may differ depending on medium and installation.

We recommend to calibrate the number of pulses per litre in line with the complete installation.

Measurement Curve FHKU Ø1.20mm (#938-7512/FTL02)

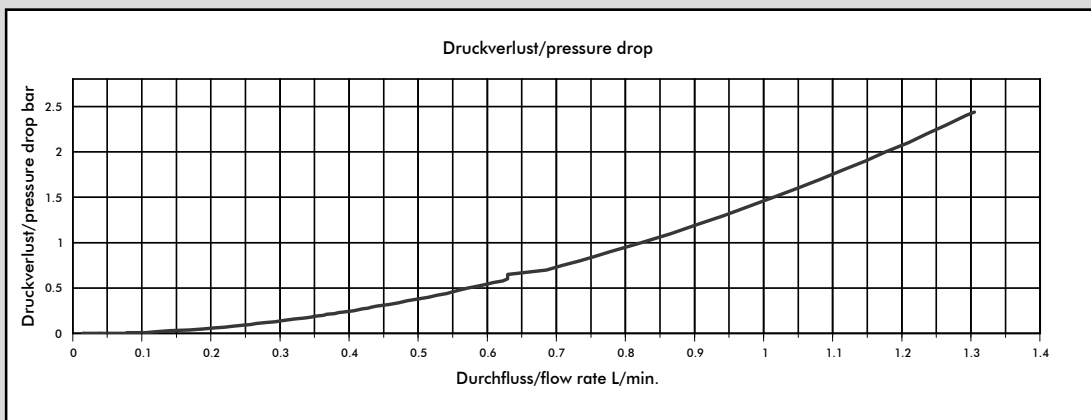
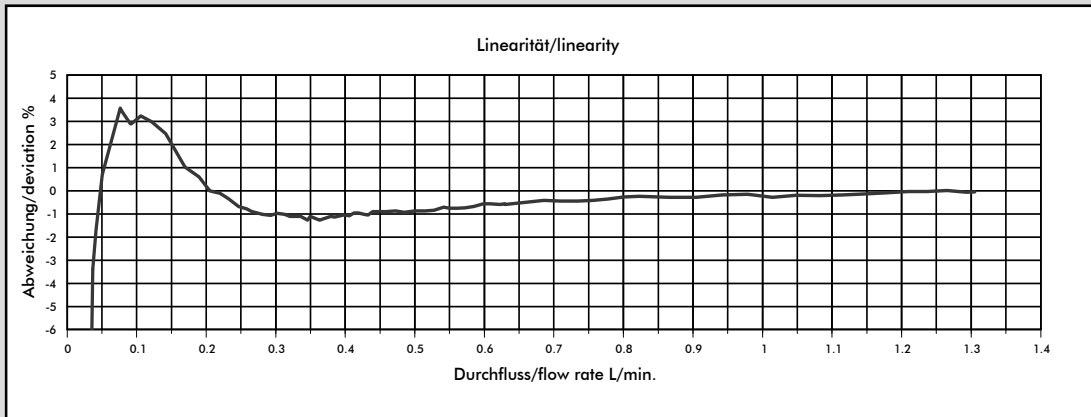

Getestet mit Wasser, max. Druck: 3.3 bar / Tested with water, max. pressure 3.3 bar

Nozzle size	Pulses/litre	g/pulse	min. flow rate in [litres/min] at linear start	max. flow rate in [litres/min]	Pressure loss in [bar]
Ø 1.00 mm	2063	0.48	0.041	0.56	1.0
Ø 1.20 mm	1700	0.59	0.050	0.82	1.0
Ø 2.00 mm	988	1.00	0.091	2.40	1.0
Ø 2.50 mm	760	1.31	0.150	3.74	1.0
Ø 3.00 mm	565	1.76	0.102	5.63	1.0
Ø 4.00 mm	381	2.62	0.123	8.38	0.8
Ø 5.60 mm	236	4.22	0.308	9.26	0.5

MEASUREMENT TIPS

- Ensure that there is no fast-pulsatory movement of the media
- Ensure that there are no reverse pressure surges
- Ensure that there is no air in the system
- Keep the pressure loss as small as possible
- Note the mounting position of the flowmeter
- Min/max flow should be in the linear range of the selected flowmeter
- Clean the system at appropriate intervals
- Avoid electrical current peaks
- Incorrect cabling of power supply +, signal and ground will destroy the flowmeter
- Do not mechanically load electrical contacts
- Avoid moisture on the electrical contacts
- Avoid stray pick-up via the cable (Do not lay cables in parallel with high current loads)

The values specified must be considered as approximate values.

The number of pulses per litre may differ depending on medium and installation.

We recommend to calibrate the number of pulses per litre in line with the complete installation.

Measurement Curve FHKU Ø2.00mm (#938-7520/FTL02)

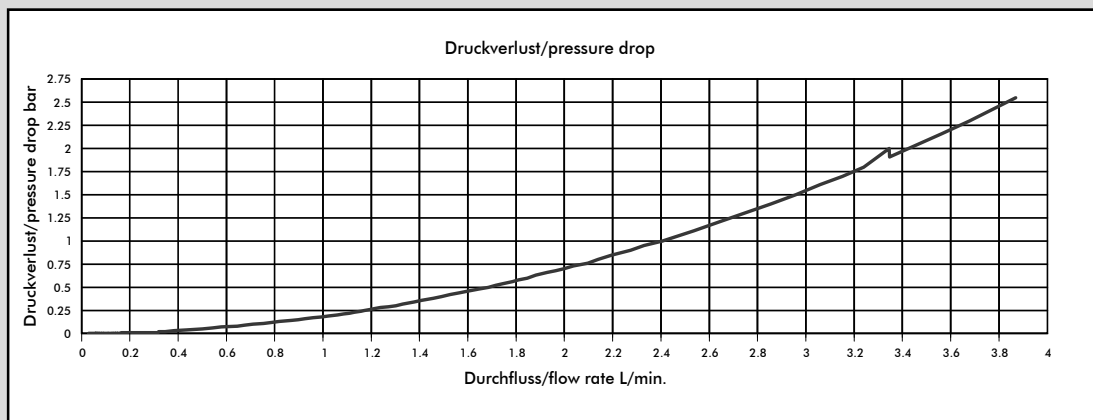
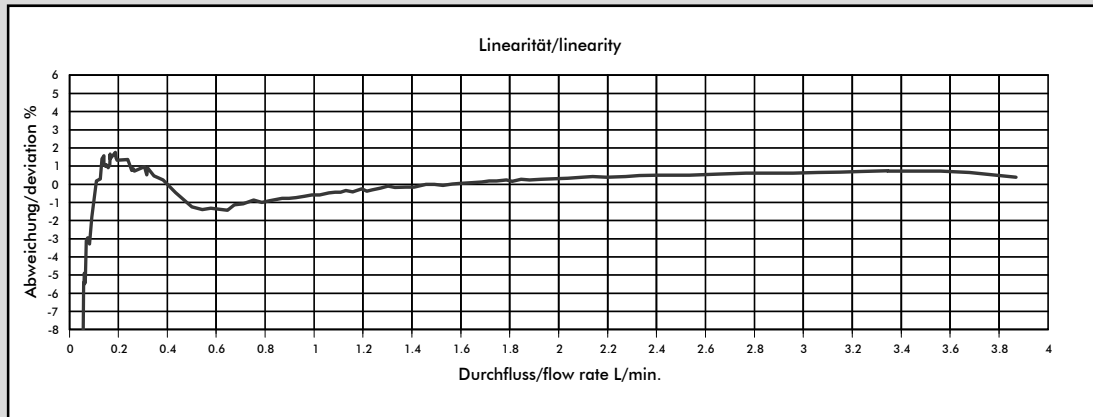

Getestet mit Wasser, max. Druck: 3.3 bar / Tested with water, max. pressure 3.3

Nozzle size	Pulses/litre	g/pulse	min. flow rate in [litres/min] at linear start	max. flow rate in [litres/min]	Pressure loss in [bar]
Ø 1.00 mm	2063	0.48	0.041	0.56	1.0
Ø 1.20 mm	1700	0.59	0.050	0.82	1.0
Ø 2.00 mm	988	1.00	0.091	2.40	1.0
Ø 2.50 mm	760	1.31	0.150	3.74	1.0
Ø 3.00 mm	565	1.76	0.102	5.63	1.0
Ø 4.00 mm	381	2.62	0.123	8.38	0.8
Ø 5.60 mm	236	4.22	0.308	9.26	0.5

MEASUREMENT TIPS

- Ensure that there is no fast-pulsatory movement of the media
- Ensure that there are no reverse pressure surges
- Ensure that there is no air in the system
- Keep the pressure loss as small as possible
- Note the mounting position of the flowmeter
- Min/max flow should be in the linear range of the selected flowmeter
- Clean the system at appropriate intervals
- Avoid electrical current peaks
- Incorrect cabling of power supply +, signal and ground will destroy the flowmeter
- Do not mechanically load electrical contacts
- Avoid moisture on the electrical contacts
- Avoid stray pick-up via the cable (Do not lay cables in parallel with high current loads)

The values specified must be considered as approximate values.

The number of pulses per litre may differ depending on medium and installation.

We recommend to calibrate the number of pulses per litre in line with the complete installation.

Measurement Curve FHKU Ø2.50mm (#938-7525/FTL02)

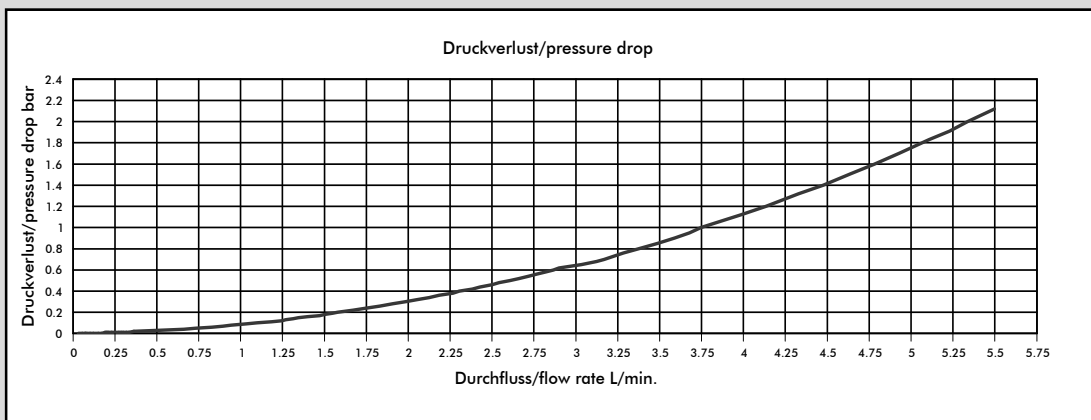
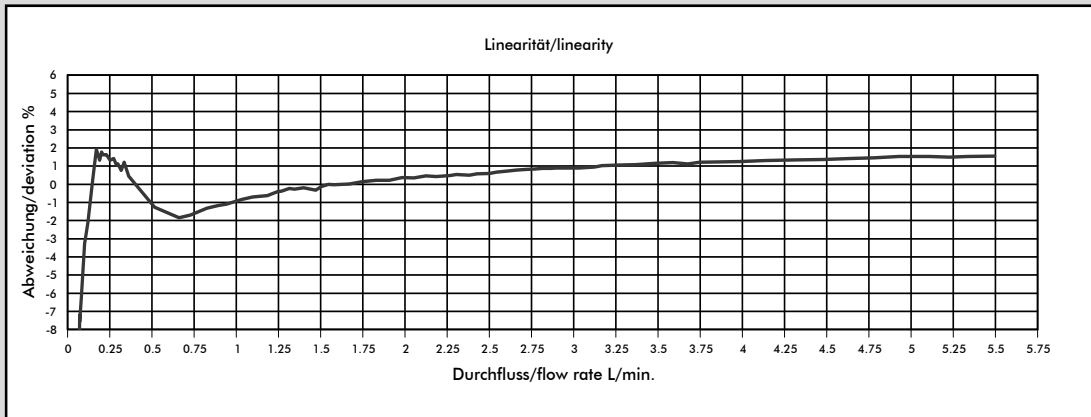

Getestet mit Wasser, max. Druck: 3.3 bar / Tested with water, max. pressure 3.3 bar

Nozzle size	Pulses/litre	g/pulse	min. flow rate in [litres/min] at linear start	max. flow rate in [litres/min]	Pressure loss in [bar]
Ø 1.00 mm	2063	0.48	0.041	0.56	1.0
Ø 1.20 mm	1700	0.59	0.050	0.82	1.0
Ø 2.00 mm	988	1.00	0.091	2.40	1.0
Ø 2.50 mm	760	1.31	0.150	3.74	1.0
Ø 3.00 mm	565	1.76	0.102	5.63	1.0
Ø 4.00 mm	381	2.62	0.123	8.38	0.8
Ø 5.60 mm	236	4.22	0.308	9.26	0.5

MEASUREMENT TIPS

- Ensure that there is no fast-pulsatory movement of the media
- Ensure that there are no reverse pressure surges
- Ensure that there is no air in the system
- Keep the pressure loss as small as possible
- Note the mounting position of the flowmeter
- Min/max flow should be in the linear range of the selected flowmeter
- Clean the system at appropriate intervals
- Avoid electrical current peaks
- Incorrect cabling of power supply +, signal and ground will destroy the flowmeter
- Do not mechanically load electrical contacts
- Avoid moisture on the electrical contacts
- Avoid stray pick-up via the cable (Do not lay cables in parallel with high current loads)

The values specified must be considered as approximate values.

The number of pulses per litre may differ depending on medium and installation.

We recommend to calibrate the number of pulses per litre in line with the complete installation.

Measurement Curve FHKU Ø3.00mm (#938-7530/TL02)

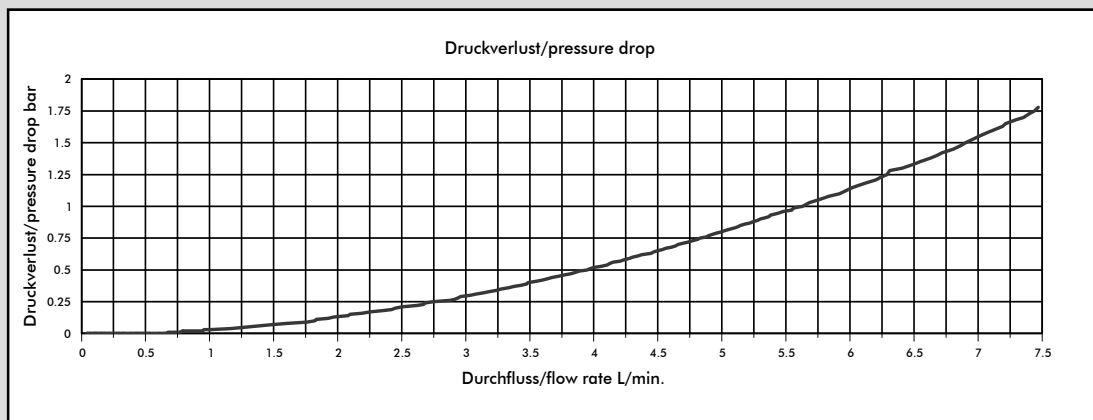
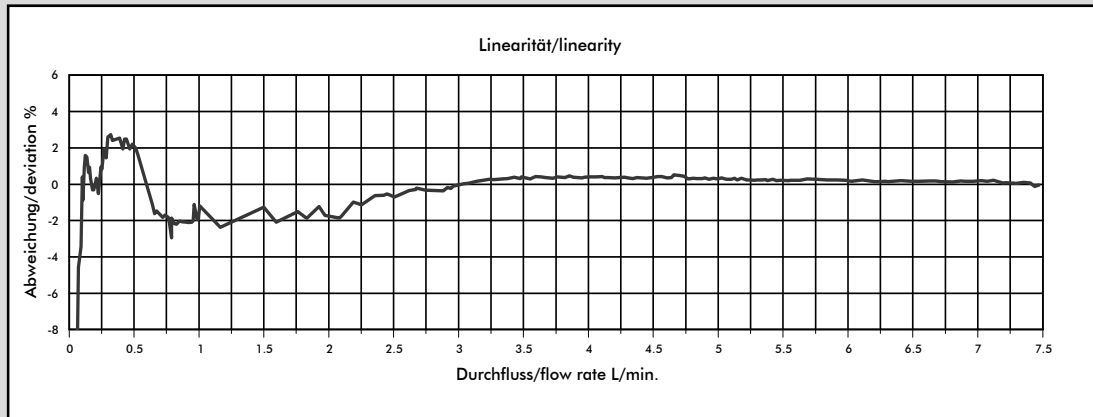

Getestet mit Wasser, max. Druck: 3.3 bar / Tested with water, max. pressure 3.3 bar

Nozzle size	Pulses/litre	g/pulse	min. flow rate in [litres/min] at linear start	max. flow rate in [litres/min]	Pressure loss in [bar]
Ø 1.00 mm	2063	0.48	0.041	0.56	1.0
Ø 1.20 mm	1700	0.59	0.050	0.82	1.0
Ø 2.00 mm	988	1.00	0.091	2.40	1.0
Ø 2.50 mm	760	1.31	0.150	3.74	1.0
Ø 3.00 mm	565	1.76	0.102	5.63	1.0
Ø 4.00 mm	381	2.62	0.123	8.38	0.8
Ø 5.60 mm	236	4.22	0.308	9.26	0.5

MEASUREMENT TIPS

- Ensure that there is no fast-pulsatory movement of the media
- Ensure that there are no reverse pressure surges
- Ensure that there is no air in the system
- Keep the pressure loss as small as possible
- Note the mounting position of the flowmeter
- Min/max flow should be in the linear range of the selected flowmeter
- Clean the system at appropriate intervals
- Avoid electrical current peaks
- Incorrect cabling of power supply +, signal and ground will destroy the flowmeter
- Do not mechanically load electrical contacts
- Avoid moisture on the electrical contacts
- Avoid stray pick-up via the cable (Do not lay cables in parallel with high current loads)

The values specified must be considered as approximate values.

The number of pulses per litre may differ depending on medium and installation.

We recommend to calibrate the number of pulses per litre in line with the complete installation.

Measurement Curve FHKU Ø4.00mm (#938-7540/TL02)

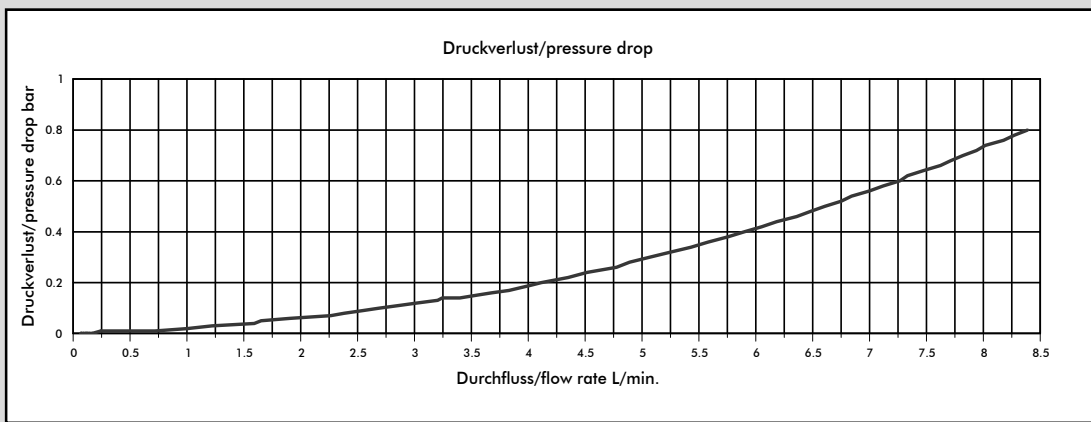
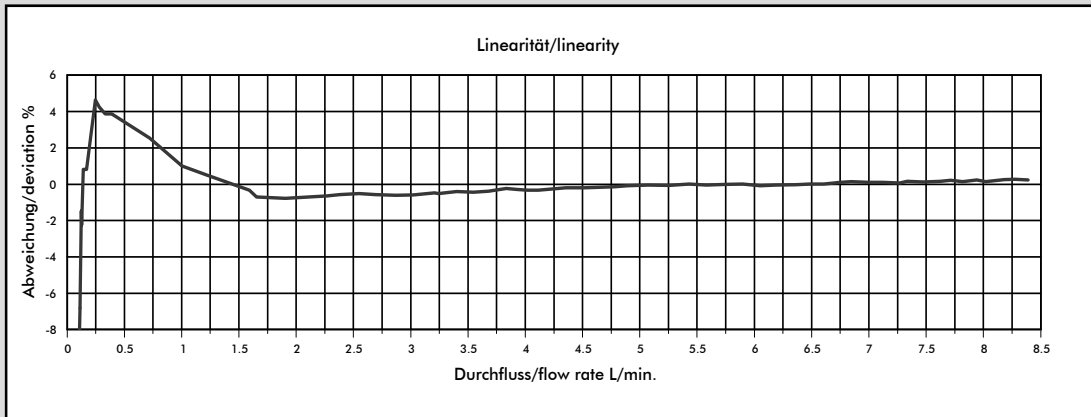

Getestet mit Wasser, max. Druck: 3.3 bar / Tested with water, max. pressure 3.3 bar

Nozzle size	Pulses/litre	g/pulse	min. flow rate in [litres/min] at linear start	max. flow rate in [litres/min]	Pressure loss in [bar]
Ø 1.00 mm	2063	0.48	0.041	0.56	1.0
Ø 1.20 mm	1700	0.59	0.050	0.82	1.0
Ø 2.00 mm	988	1.00	0.091	2.40	1.0
Ø 2.50 mm	760	1.31	0.150	3.74	1.0
Ø 3.00 mm	565	1.76	0.102	5.63	1.0
Ø 4.00 mm	381	2.62	0.123	8.38	0.8
Ø 5.60 mm	236	4.22	0.308	9.26	0.5

MEASUREMENT TIPS

- Ensure that there is no fast-pulsatory movement of the media
- Ensure that there are no reverse pressure surges
- Ensure that there is no air in the system
- Keep the pressure loss as small as possible
- Note the mounting position of the flowmeter
- Min/max flow should be in the linear range of the selected flowmeter
- Clean the system at appropriate intervals
- Avoid electrical current peaks
- Incorrect cabling of power supply +, signal and ground will destroy the flowmeter
- Do not mechanically load electrical contacts
- Avoid moisture on the electrical contacts
- Avoid stray pick-up via the cable (Do not lay cables in parallel with high current loads)

The values specified must be considered as approximate values.

The number of pulses per litre may differ depending on medium and installation.

We recommend to calibrate the number of pulses per litre in line with the complete installation.

Measurement Curve FHKU Ø5.60mm (#938-7556/TL02)

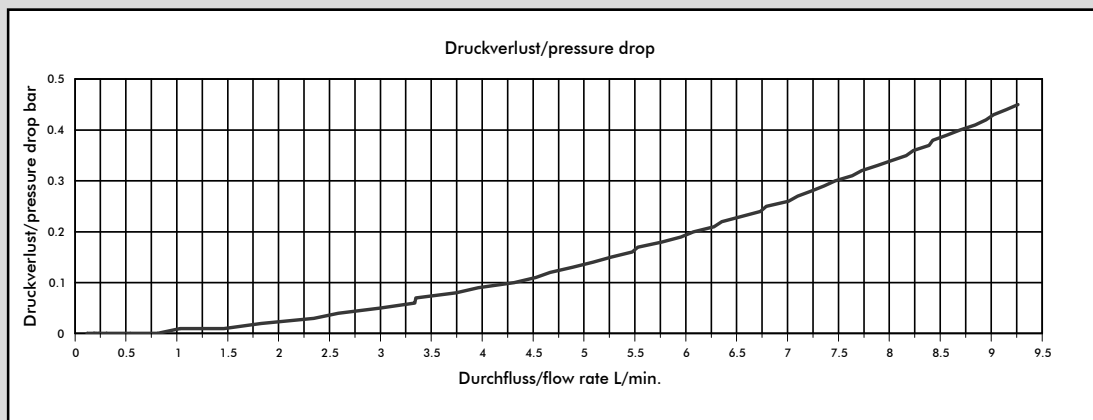
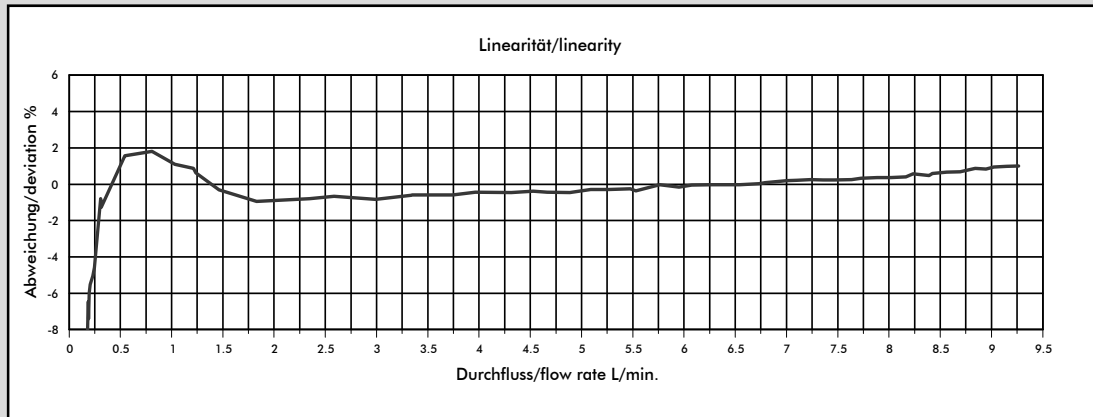

Getestet mit Wasser, max. Druck: 3.3 bar / Tested with water, max. pressure 3.3 bar

Nozzle size	Pulses/litre	g/pulse	min. flow rate in [litres/min] at linear start	max. flow rate in [litres/min]	Pressure loss in [bar]
Ø 1.00 mm	2063	0.48	0.041	0.56	1.0
Ø 1.20 mm	1700	0.59	0.050	0.82	1.0
Ø 2.00 mm	988	1.00	0.091	2.40	1.0
Ø 2.50 mm	760	1.31	0.150	3.74	1.0
Ø 3.00 mm	565	1.76	0.102	5.63	1.0
Ø 4.00 mm	381	2.62	0.123	8.38	0.8
Ø 5.60 mm	236	4.22	0.308	9.26	0.5

MEASUREMENT TIPS

- Ensure that there is no fast-pulsatory movement of the media
- Ensure that there are no reverse pressure surges
- Ensure that there is no air in the system
- Keep the pressure loss as small as possible
- Note the mounting position of the flowmeter
- Min/max flow should be in the linear range of the selected flowmeter
- Clean the system at appropriate intervals
- Avoid electrical current peaks
- Incorrect cabling of power supply +, signal and ground will destroy the flowmeter
- Do not mechanically load electrical contacts
- Avoid moisture on the electrical contacts
- Avoid stray pick-up via the cable (Do not lay cables in parallel with high current loads)

The values specified must be considered as approximate values.

The number of pulses per litre may differ depending on medium and installation.

We recommend to calibrate the number of pulses per litre in line with the complete installation.